

Eight-Channel, Serial Interface, Low-side Driver

PRODUCT DESCRIPTION

The MS31860T is a eight-channel low-side driver and includes SPI communication, PWM chopper configuration, overcurrent protection, short-circuit protection, undervoltage lockout and overtemperature shutdown functions. The MS31860T can read the state of each channel. In addition, it could diagnose load condition of open-circuit and read fault information, which is indicated by external fault pin.

The MS31860T can provide up to 200mA duration current for each channel (eight channels are enabled). When single channel is enabled, maximum 560mA duration current is available.

Multiple MS31860Ts can be connected together through daisy chain and use one single serial interface. And current and chopper are configured by serial interface.

The MS31860T can provide output current for eight channels or single channel.

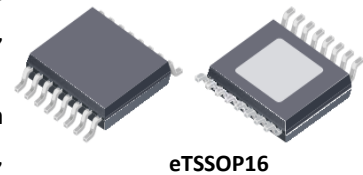

eTSSOP16

FEATURES

- Eight-channel Low-side Driver
 - Eight NMOS FETs with OCP Function
 - Integrated High-side Body Diode
 - Serial Interface
 - Configurable PWM Duty Cycle
- Power Supply: 6.5V to 38V
- Digital Input Filter
- Read Function for Internal Data
- Protection and Diagnose Characteristics
 - Overcurrent Protection (OCP)
 - Open-circuit Load Detection (OL)
 - Overtemperature Shutdown (OTS)
 - Undervoltage Lockout (UVLO)
 - Dependent Channel State Report
 - Fault Alarm

APPLICATIONS

- Relay, Unipolar Stepper Motor
- Solenoid, Electromagnetic Driver
- Common Low-side Switch Applications

PRODUCT SPECIFICATION

Part Number	Package	Marking
MS31860T	eTSSOP16	MS31860T

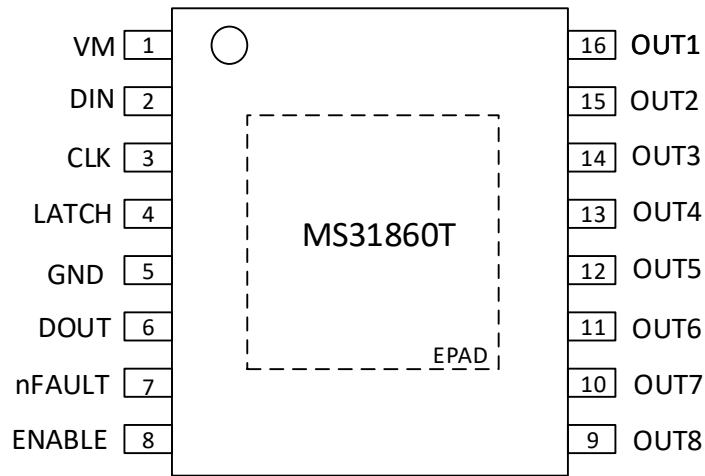
PIN CONFIGURATION

PIN DESCRIPTION

Pin	Name	Type	Description
1	VM	-	Power Supply
2	DIN	I	Data Input
3	CLK	I	Clock Input
4	LATCH	I	Register Enable
5	GND	-	Ground
6	DOUT	O	Data Output
7	nFAULT	OD	Fault Indication Pin
8	ENABLE	I	Output Enable Pin
9	OUT8	O	Low-side Output Pin OUT8
10	OUT7	O	Low-side Output Pin OUT7
11	OUT6	O	Low-side Output Pin OUT6
12	OUT5	O	Low-side Output Pin OUT5
13	OUT4	O	Low-side Output Pin OUT4
14	OUT3	O	Low-side Output Pin OUT3
15	OUT2	O	Low-side Output Pin OUT2
16	OUT1	O	Low-side Output Pin OUT1
-	EPAD	-	Thermal Pad, need to ground

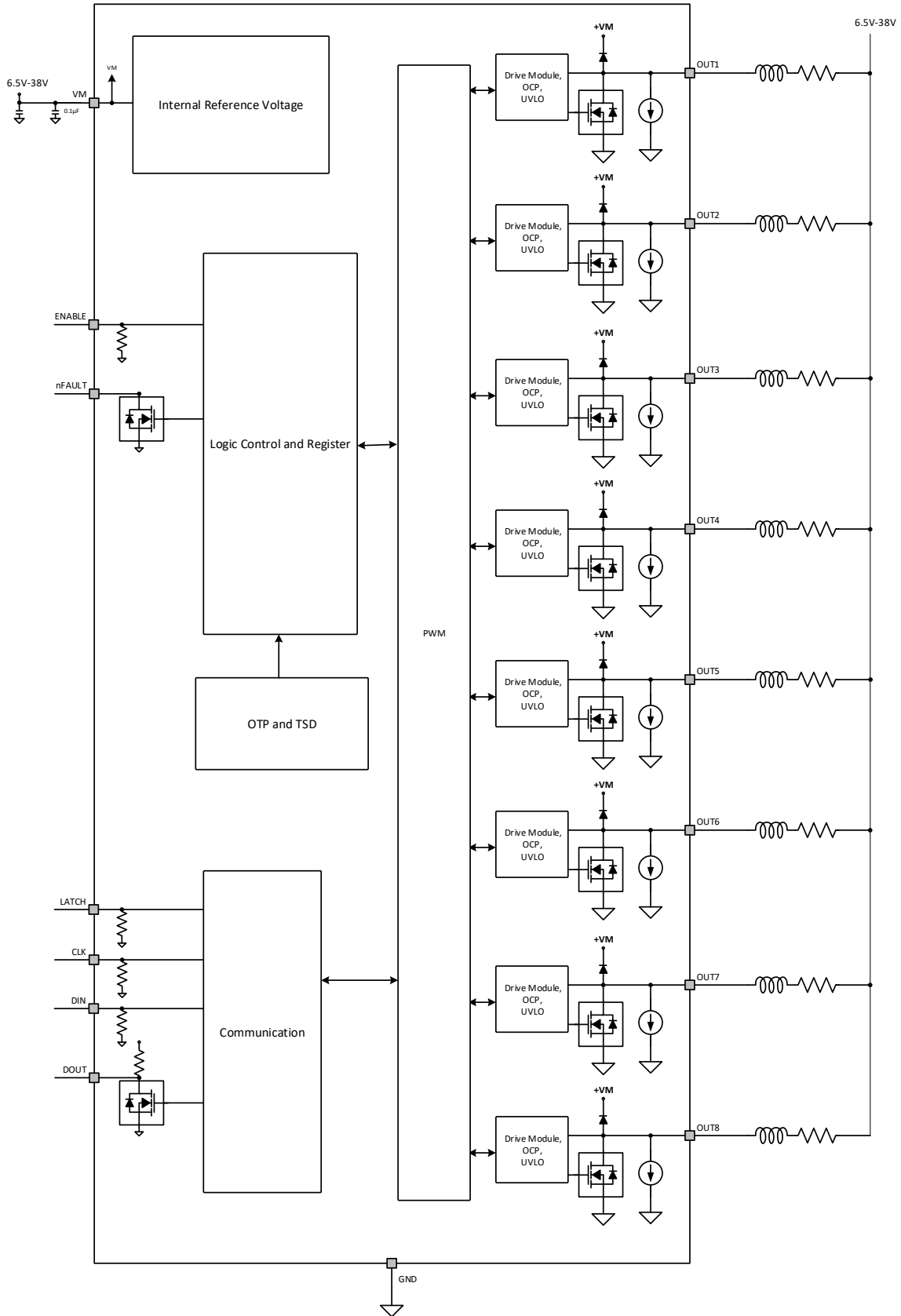
BLOCK DIAGRAM



ABSOLUTE MAXIMUM RATINGS

Any exceeding absolute maximum rating application causes permanent damage to device. Because long-time absolute operation state affects device reliability. Absolute ratings just conclude from a series of extreme tests. It doesn't represent chip can operate normally in these extreme conditions.

Parameter	Symbol	Ratings	Unit
Supply Voltage	V_M	-0.3 ~ 40	V
Digital Input Current	$I_{ENABLE}, I_{LATCH}, I_{CLK}, I_{DIN}$	0 ~ 20	mA
Digital Output Voltage	V_{DOUT}, V_{nFAULT}	-0.5 ~ 6	V
Digital Output Current	I_{DOUT}, I_{nFAULT}	10	mA
Output Voltage	V_{OUTx}	-0.3 ~ 40	V
Output Current	I_{OUTx}	0.6	A
Operating Temperature	T_A	-40 ~ 150	°C
ESD (HBM)	V_{ESD}	4	kV

RECOMMENDED OPERATING CONDITIONS

Parameter	Symbol	Range			Unit
		Min	Typ	Max	
Supply Voltage	V_M	6.5		38	V
Operating Temperature	T_A	-40		85	°C

ELECTRICAL CHARACTERISTICS

Within supply voltage and operating temperature ranges.

Power Supply

Parameter	Symbol	Condition	Min	Typ	Max	Unit
Supply Current	I_{DD}	$V_M=24V$		3		mA
Undervoltage Lockout	V_{UVLO}	V_M rising		5.9		V

Logic Input

Parameter	Symbol	Condition	Min	Typ	Max	Unit
Input Low-level Voltage	$V_{IN(H)}$				0.7	V
Input High-level Voltage	$V_{IN(L)}$		1.8			V
Input Voltage Hysteresis	$V_{IN(HYS)}$			200		mV
Input Low-level Current	$I_{IN(L)}$	Input 0V	-20		20	μA
Input High-level Current	$I_{IN(H)}$	Input 3.3V		30		μA
Input Pull-down Resistor	R_{PD}			100		k Ω

Open-drain Output (nFAULT,DOUT)

Parameter	Symbol	Condition	Min	Typ	Max	Unit
Output Low-level Voltage	V_{OL}	$I_O=5mA$			0.5	V
Output Leakage Current	I_{OH}		-1		1	μA
Internal Pull-up Resistor	R_{PU}	Only pull-up resistor in DOUT pin internally		0.5		k Ω

Low-side Output Drive

Parameter	Symbol	Condition	Min	Typ	Max	Unit
On-Resistance	$R_{DS(ON)}$	$V_M=24V, I_O=150mA, 25^\circ C$		1.5		Ω
Output Leakage Current	I_{OFF}				30	μA

High-side Body Diode

Parameter	Symbol	Condition	Min	Typ	Max	Unit
Diode Forward Voltage	V_F	$V_M=24V, I_O=150mA, 25^\circ C$		0.9		V
Output Leakage Current	I_{OUT}	$V_M=24V$			50	μA

Protection Circuit

Parameter	Symbol	Condition	Min	Typ	Max	Unit
Overcurrent Protection Point	I _{OCP}	Detect each channel separately			0.7	A
Open-circuit Detection Pull-down Current	I _{OL}	Detect each channel separately		30		μA
Open-circuit Detection Voltage Threshold	V _{OL}	Detect each channel separately		1.2		V
Overtemperature Protection Point	T _{TSD}	Temperature rising		160		°C
Overtemperature Protection Hysteresis	T _{HYS}			35		°C

PWM Chopping Frequency

Parameter	Symbol	Condition	Min	Typ	Max	Unit
PWM Chopping Frequency	f _{PWM}	Duty cycle > 25%		50		kHz
		Duty cycle = 25%		25		kHz
		Duty cycle = 12.5%		12.5		kHz

Timing

Parameter	Symbol	Condition	Min	Typ	Max	Unit
Input to Output Delay	t _{PD}				150	ns
Output Fall Time	t _{FALL}	150mA, V _M =24V, Resistive load	50		300	ns
Output Rise Time	t _{RISE}	150mA, V _M =24V, Resistive load	50		300	ns
OCP Detection Time	t _{OCP}	V _M =24V		3.5		μs
Open-circuit Detection Time	t _{OL}	Detect each channel separately		17		μs

FUNCTION DESCRIPTION

The MS31860T is a eight-channel low-side driver, which has overcurrent protection and open-circuit/short-circuit load detection functions. Internal integrated high-side body diode can be used to drive unipolar stepper motor, DC motor, relay, solenoid or other loads.

The MS31860T can provide up to 180mA duration output current for each channel when eight channels are all enabled. When single channel is enabled, 560mA duration output current is available. Refer to current capacity table for details

The MS31860T provides one serial interface to control output driver, configure internal setting register and read the fault state of each channel. Multiple MS31860Ts can adopt daisy chain to connect together and use same one serial interface. On addition, the energizing time and PWM duty cycle holding are configured via serial interface. Compared with traditional all-enabled solution, these functions are used to realize lower operating temperature.

The MS31860T provides perfect protection functions: overcurrent protection, short-circuit protection, undervoltage lockout and thermal shutdown. The MS31860T can diagnose open-circuit load condition. The fault information of each channel is read by serial interface and indicated by one external fault pin.

1. Recommended Output Current

The output current capacity of the MS31860T depends on some factors, including ambient temperature, maximum surface temperature, output duty cycle. Recommended output currents are as follows:

Recommended Output Current	
Configuration	Output Current Capacity
Enable 1 Output	566mA
Enable 2 Outputs	400mA
Enable 4 Outputs	283mA
Enable 8 Outputs	200mA

2. Daisy Chain

The MS31860T can adopt daisy chain and control two or multiple chips through serial interface. Previous DOUT pin is as next DIN pin input, other interfaces are used in common. Data is input from the first DIN and read from last DOUT as follows.

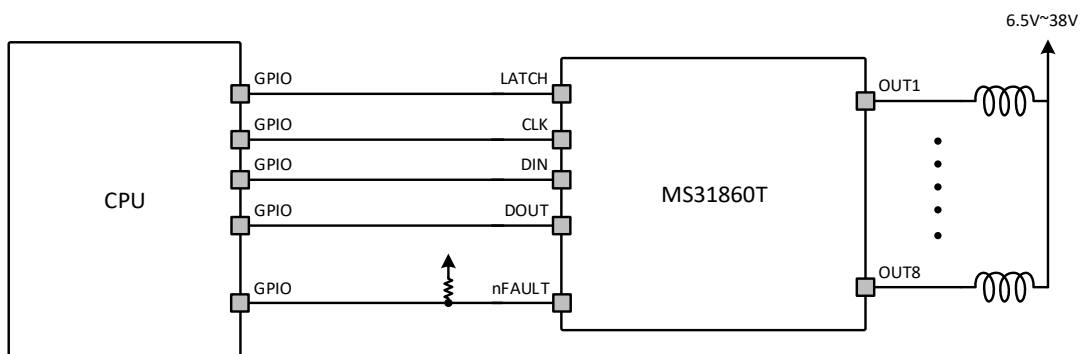

Figure 1. Single MS31860T Connection

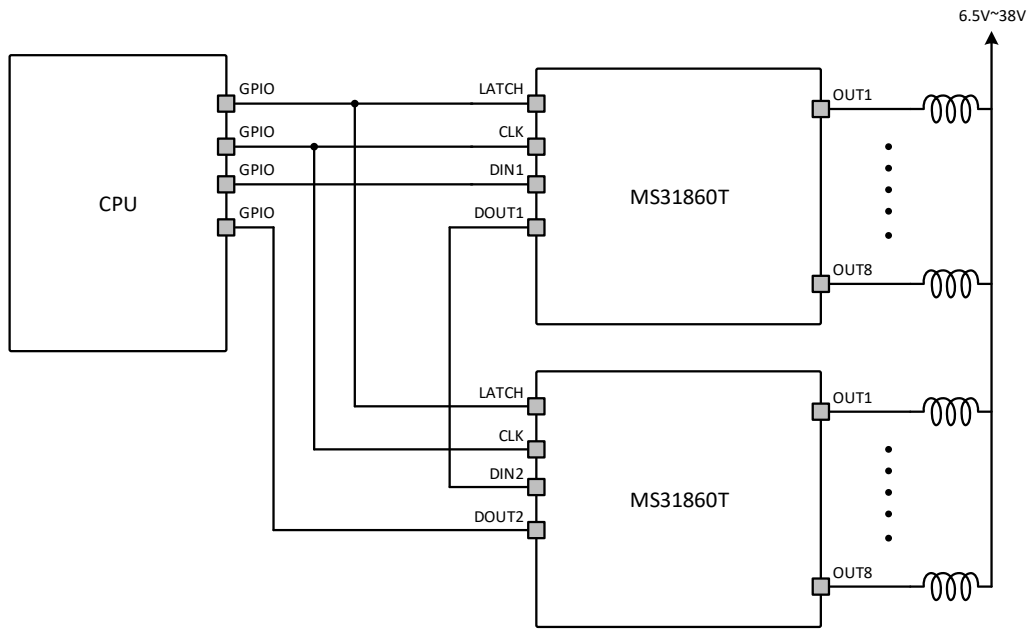

Figure 2. Multiple MS31860Ts Daisy Chain

3. Protection Circuit

The MS31860T has protection functions: undervoltage lockout (UVLO), overcurrent protection (OCP) and overtemperature protection (OTP). When these functions are triggered, shutdown operation is triggered to protect chip and motor.

3.1 OCP

When output current exceeds OCP trigger level, corresponding output channel is off. nFAULT pin is pulled down and OCP flag bit of fault register is set to 1.

When corresponding channel is off by register or write into fault reset command, fault flag would be cleared. And nFAULT pin is released and OCP flag bit is cleared.

3.2 Open-circuit Detection

When output is off, there is a 30 μ A pull-down current. If pin voltage is detected to be less than 1.2V at this time, it is judged as open-circuit load condition. nFAULT pin is set to low-level and open-circuit detection bit is set in the fault register.

When setting register enables corresponding channel, fault bit would be cleared. Or the fault indication is cleared by fault reset command.

3.3 OTP

When chip temperature exceeds temperature limit, OTP would be triggered. All outputs are disabled and nFAULT pin outputs low-level.

If chip temperature falls to normal, the fault would be cleared automatically and channel would recover operation.

3.4 UVLO

When VM pin voltage is less than undervoltage lockout threshold, all channels of the MS31860T are disabled and internal logic is reset. When VM rise to above ULVO, the MS31860T will recover normal operation. nFAULT pin is not pulled down when undervoltage is triggered.

3.5 Digital Noise Filtering

Each digital pin input of the MS31860T all has filtering circuit to ensure that data is not interfered and allow daisy chain to perform safely. If there is no input filter, output state will be effected by input noise or enter uncertain state. The digital input filter is realized by capacitor, which could filter needless noise frequency signal and ensure high-speed serial interface communication.

4. Function Mode Description

4.1 Internal Register

The MS31860T is controlled by SPI, including three groups of registers: data register, control register and fault register.

In default condition, the MS31860T can write into data register group and read from fault register group. Read and write commands of other register groups need some special commands to operate.

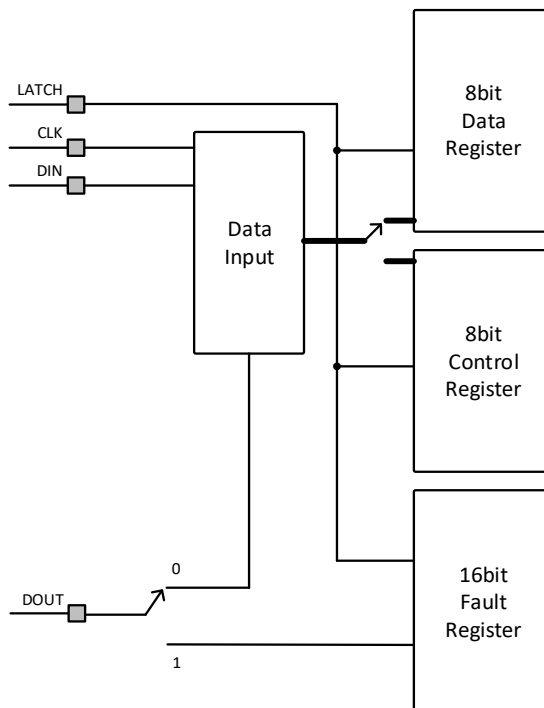

Figure 3. Register Overview

4.2 Basic Function

In the condition without any configuration, 8bit shift register shifts data into data register group and data is output through daisy chain. At this time, serial input data will directly control FET.

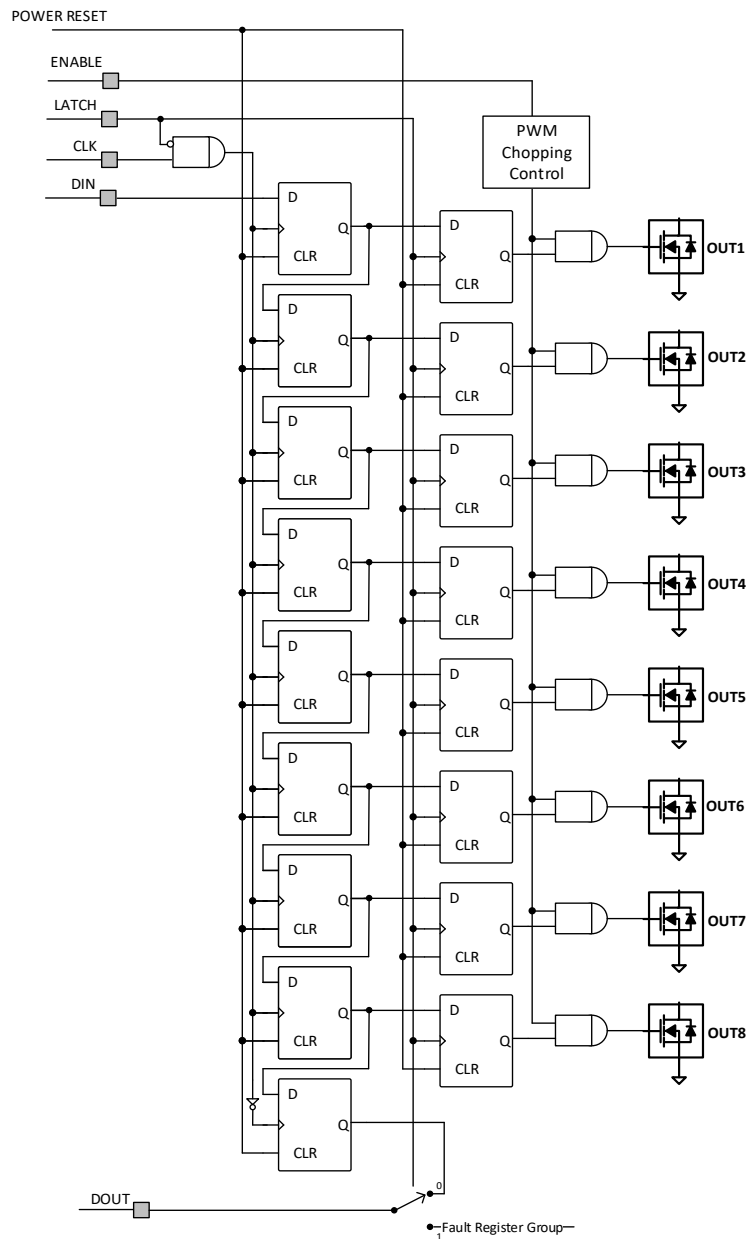

Figure 4. 8bit Shift Register

4.3 Register Group

Register Group		D8	D7	D6	D5	D4	D3	D2	D1
Data Register Group		OUT8	OUT7	OUT6	OUT5	OUT4	OUT3	OUT2	OUT1
Fault Register Group	High 8bit	OCP8	OCP7	OCP6	OCP5	OCP4	OCP3	OCP2	OCP1
	Low 8bit	OL8	OL7	OL6	OL5	OL4	OL3	OL2	OL1
Control Register Group		PWM_EN	PWM Duty Cycle control			Energizing Time control			

4.4 Special Command

In order to improve efficiency, the MS31860T has some special commands to read from and write into corresponding register, including five special commands. These commands need CLK interface and LATCH interface.

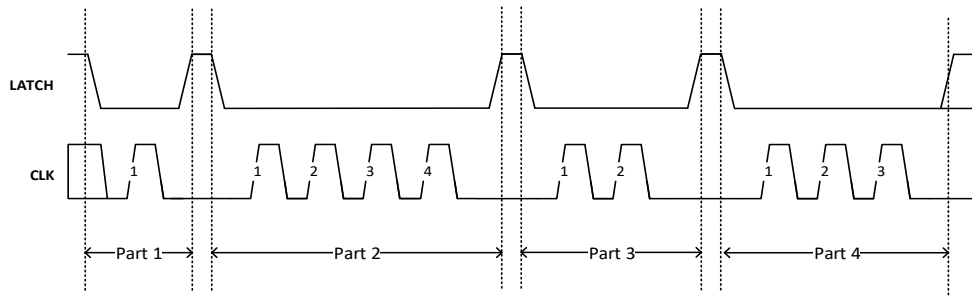

Figure 5. Control Register Group Reading Special Command

Above figure is PWM start command, referring to following table and above diagram. The MS31860T has five special commands.

Special Command	Part 1	Part 2	Part 3	Part 4
Write Control Register Group	1	2	2	3
Read Control Register Group	1	4	2	3
Read Data Register Group	1	4	4	3
Reset Fault Register Group	1	2	4	3
PWM Start	1	6	6	3

4.5 Data Register Group

Register Group	D8	D7	D6	D5	D4	D3	D2	D1
Data Register Group	OUT8	OUT7	OUT6	OUT5	OUT4	OUT3	OUT2	OUT1

4.5.1 Data Register Group Function

In default condition, 8bit data input directly controls corresponding 8bit data in data register group. However, data register group directly corresponds to the states of eight output channels. In other words, 8bit data of SPI data input would directly control on-off of eight FETs.

4.5.2 Write Data Register Group

Because the MS31860T has daisy chain function, data can be continuously input. On the clock rising edge, external data would be serially input into data input and enter into register group on the rising edge of LATCH.

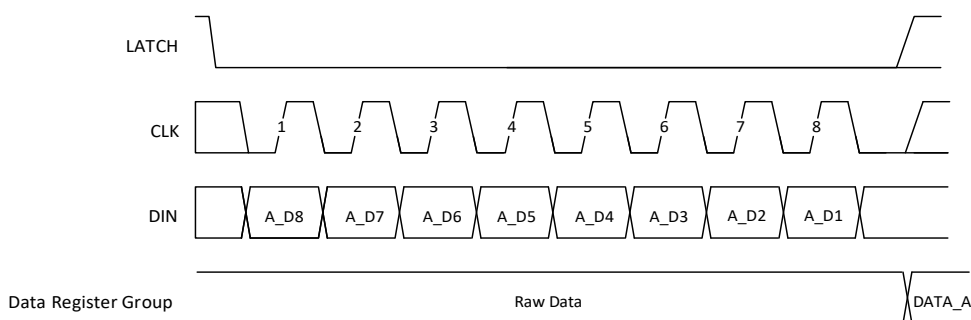

Figure 6. Write Data Register Group-Single MS31860T

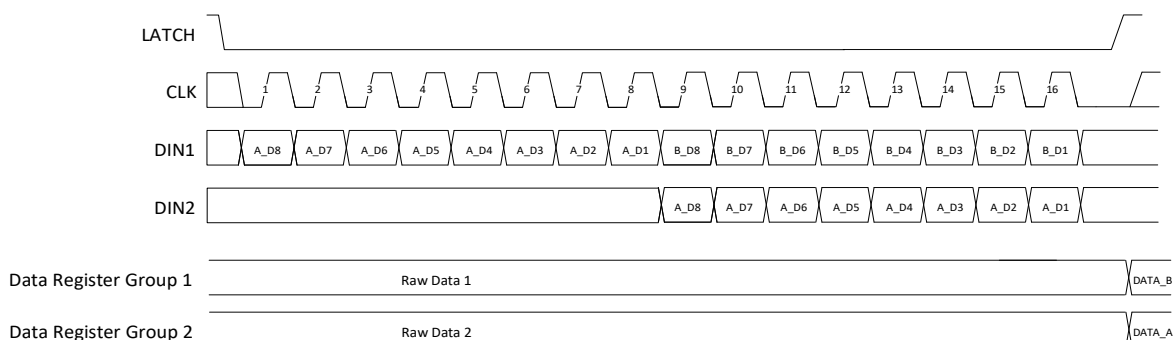

Figure 7. Write Data Register Group-Dual MS31860Ts Daisy Chain

4.5.3 Read Data Register Group

Reading data register group needs special command CODE1443 (see special command selection). After the command, one reading data register group is achieved. Each read all needs input command again. Data would be serially output from SOUT pin on the rising edge of CLK.

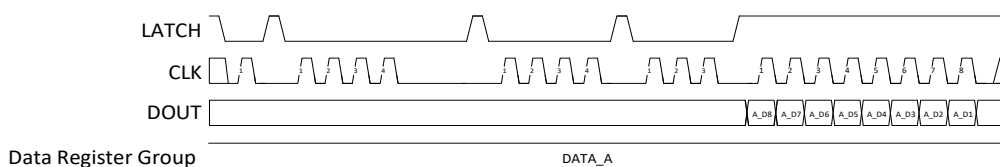

Figure 8. Read Data Register Group-Single MS31860T

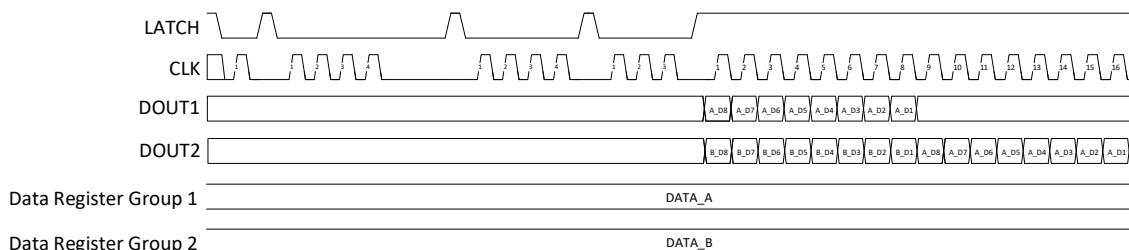

Figure 9. Read Data Register Group-Dual MS31860Ts Daisy Chain

4.6 Control Register Group

Register Group	D8	D7	D6	D5	D4	D3	D2	D1
Control Register Group	PWM_EN	PWM Duty Cycle control			Energizing Time control			

4.6.1 Control Register Group Function

Control register group has 8bit data. The MSB, D8 is PWM enabled terminal; D7~D5 configure frequency and duty cycle of PWM chopping mode; D4~D1 configure start time of PWM chopping mode.

Table 1. Configuration Table of Control Register Group

Enable Configuration	
Register Group	Configuration Result
0xxx_xxxx	Output in start state all time
1xxx_xxxx	Output control register group controlling start and PWM
Period and Duty Cycle Configurations	
1000_xxxx	Output off after start time
1001_xxxx	Frequency=12.5kHz Duty Cycle=12.5%
1010_xxxx	Frequency=25kHz Duty Cycle=25%
1011_xxxx	Frequency=50kHz Duty Cycle=37.5%
1100_xxxx	Frequency=50kHz Duty Cycle=50%
1101_xxxx	Frequency=50kHz Duty Cycle=62.5%
1110_xxxx	Frequency=50kHz Duty Cycle=75%
1111_xxxx	Frequency=50kHz Duty Cycle=87.5%
Start Time Configuration	
1xxx_0000	Start PWM chopping mode at once
1xxx_0001	Start time=3ms
1xxx_0010	Start time=5ms
1xxx_0011	Start time=10ms
1xxx_0100	Start time=15ms
1xxx_0101	Start time=20ms
1xxx_0110	Start time=30ms
1xxx_0111	Start time=50ms
1xxx_1000	Start time=80ms
1xxx_1001	Start time=110ms
1xxx_1010	Start time=140ms
1xxx_1011	Start time=170ms
1xxx_1100	Start time=200ms
1xxx_1101	Start time=230ms
1xxx_1110	Start time=260ms
1xxx_1111	Start time=300ms

The start effects of five PWM chopping modes are as follows:

1. Full Duty Cycle Start:

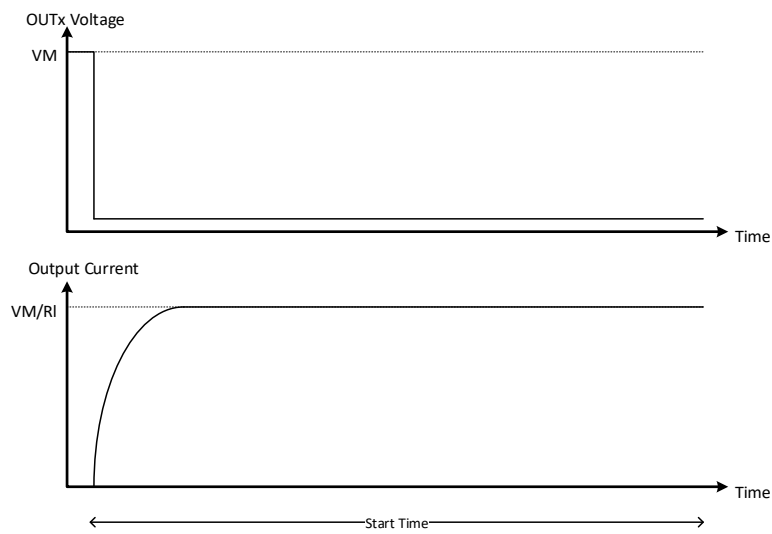

Figure 10. Start PWM Chopping with Full Duty Cycle

2. Not-Full Duty Cycle Start:

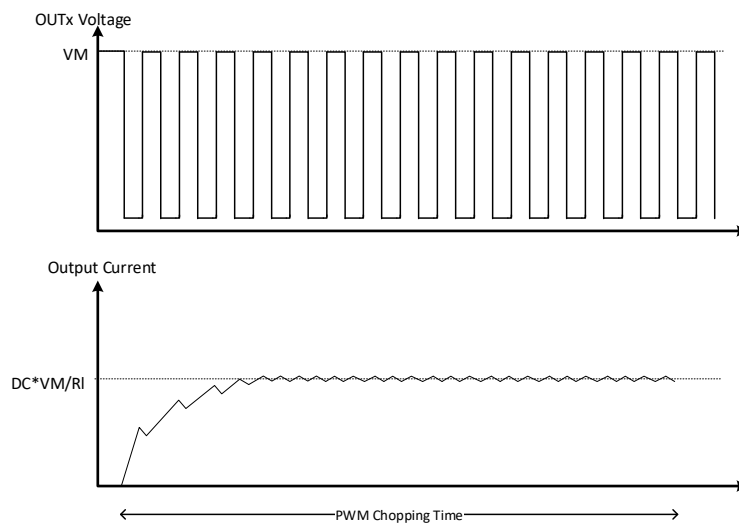
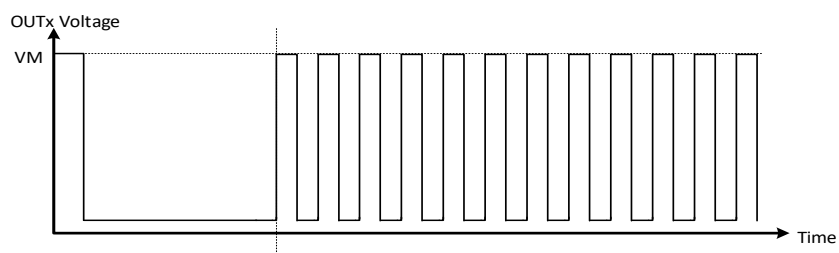

Figure 11. Start PWM Chopping with Not Full Duty Cycle

3. Not-Full Duty Cycle Operate after Full Duty Cycle Start:



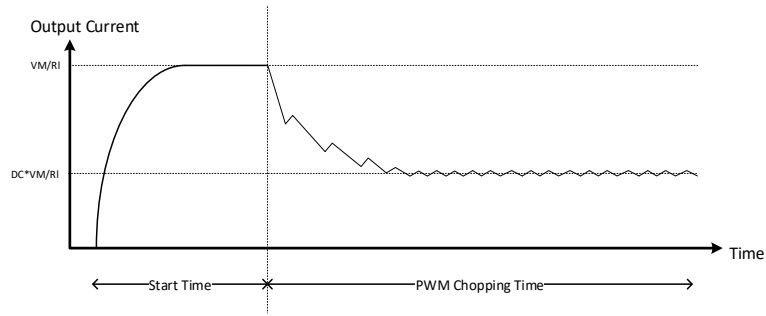

Figure 12. Operate PWM Chopping after Full Duty Cycle Start

4. Off after Full Duty Cycle Start:

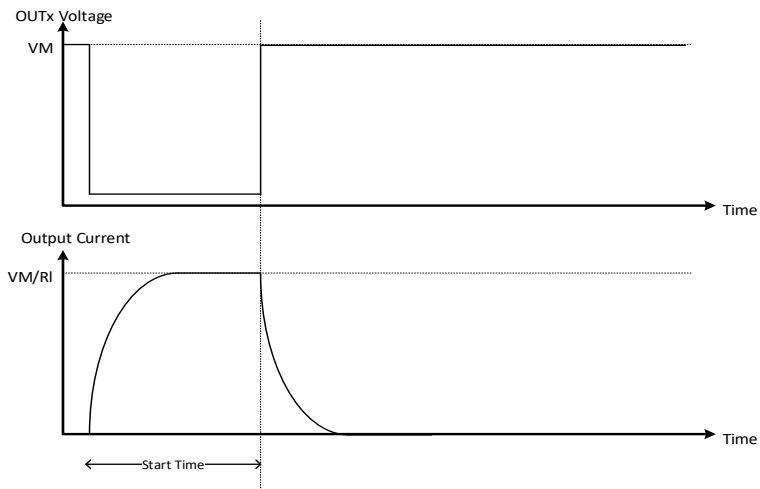

Figure 13. Disable PWM Chopping after Full Duty Cycle Start

5. Special Command Start In Advance:

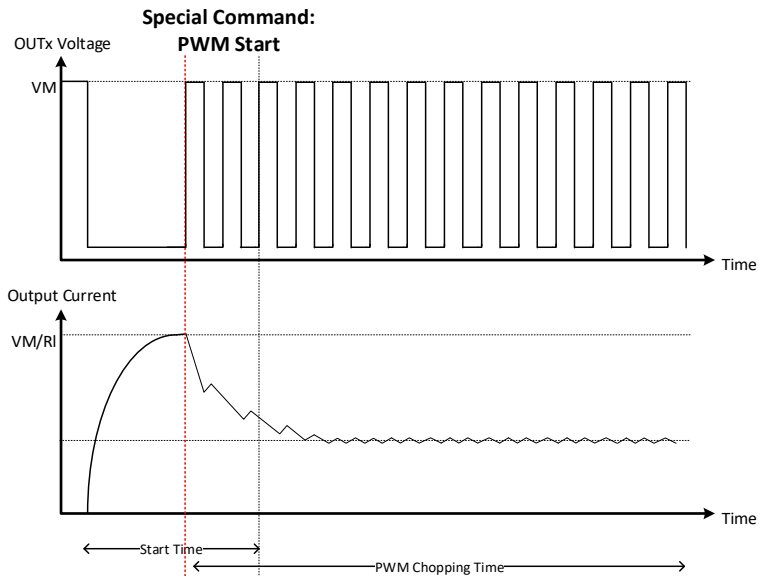

Figure 14. Special Command, Start PWM Chopping In Advance

4.6.2 Write Control Register Group

Writing control register group needs special command CODE1223 (see special command selection). After the command, one writing control register group is achieved. Each write all needs input command again.

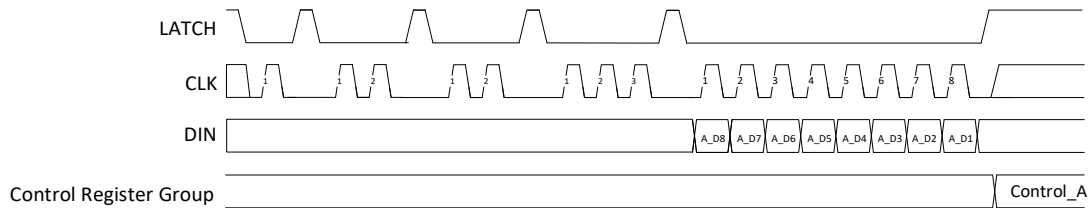

Figure 15. Write Control Register Group-Single MS31860T

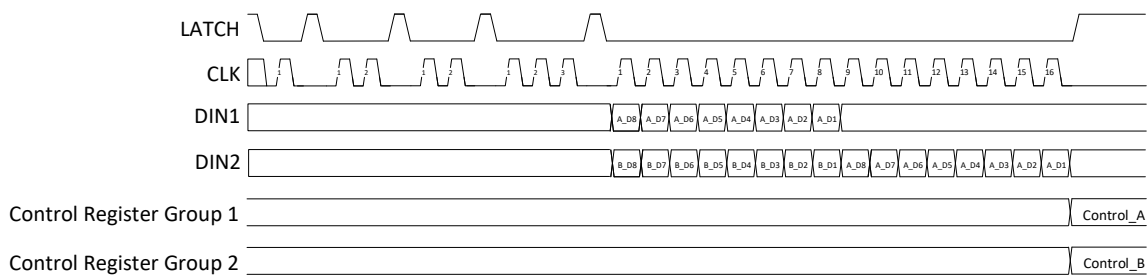

Figure 16. Write Control Register Group-Dual MS31860Ts Daisy Chain

4.6.3 Read Control Register Group

Reading control register group needs special command CODE1423 (see special command selection). After the command, one reading control register group is achieved. Each read all needs input command again. Data would be serially output from SOUT pin on the rising edge of CLK.

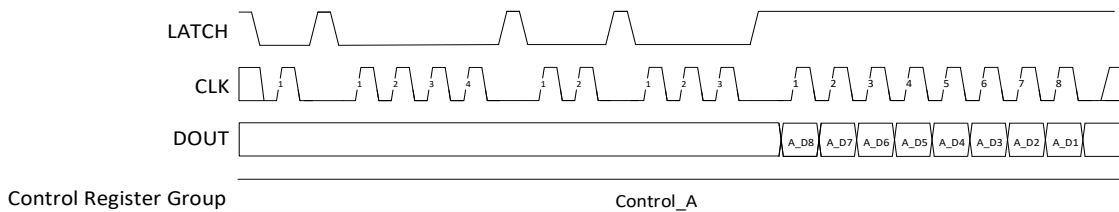

Figure 17. Read Control Register Group-Single MS31860T

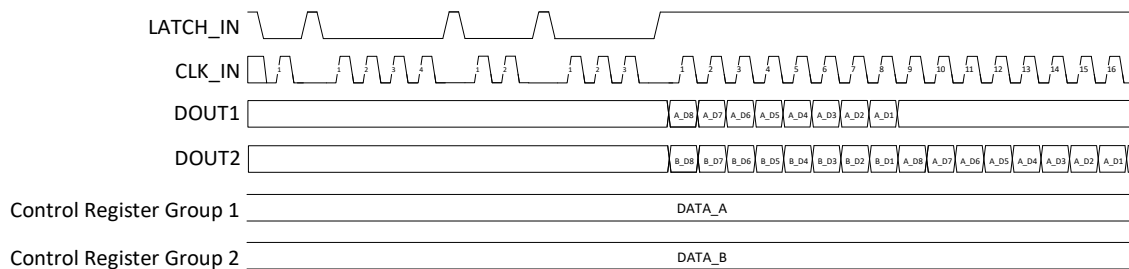

Figure 18. Read Control Register Group-Dual MS31860Ts Daisy Chain

4.7 Fault Register Group

Register Group	D16	D15	D14	D13	D12	D11	D10	D9
Fault Register Group	OCP8	OCP7	OCP6	OCP5	OCP4	OCP3	OCP2	OCP1
Register Group	D8	D7	D6	D5	D4	D3	D2	D1
Fault Register Group	OL8	OL7	OL6	OL5	OL4	OL3	OL2	OL1

4.7.1 Fault Register Group Function

Fault register group includes 16bit data to record OCP and load open-circuit condition for each channel. The corresponding condition refers to register address table.

4.7.2 Reset Fault Register Group

Fault register group are only-read registers and only can perform reset-clear operation. Special command CODE1243 (see special command selection) is needed. After reset, nFAULT pin would recover as high-level and all fault register indications are reset and cleared.

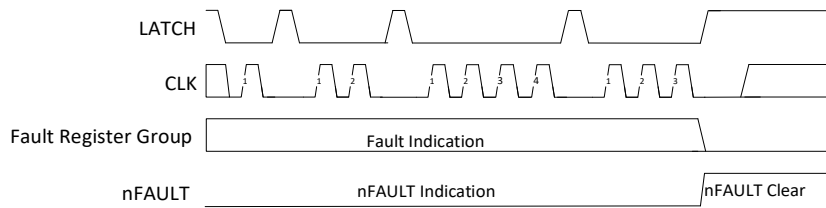

Figure 19. Reset Fault Register Group

4.7.3 Read Fault Register Group

In default condition, fault register group can be read without need of special command.

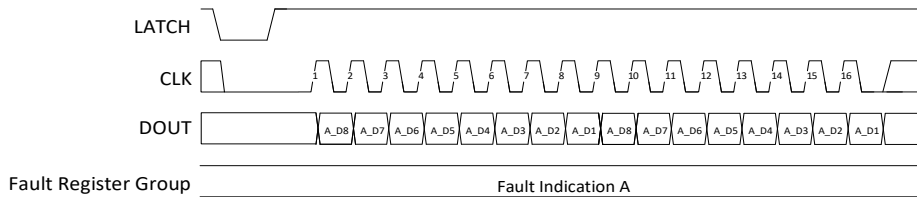

Figure 20. Read Fault Register Group-Single MS31860T

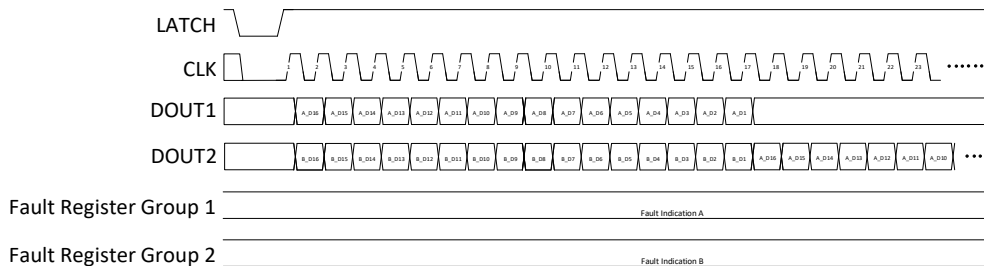

Figure 21. Read Fault Register Group-Dual MS31860Ts Daisy Chain

4.8 Special Command: PWM Start

PWM start needs special command CODE1663 (see special command selection). After the command, the MS31860T directly enters into PWM chopping mode.

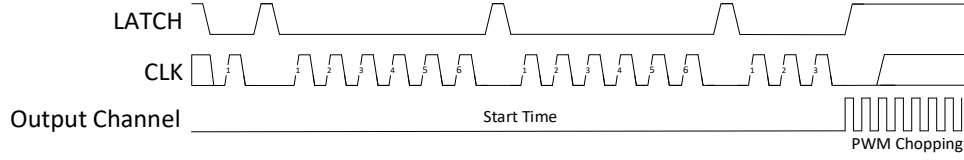
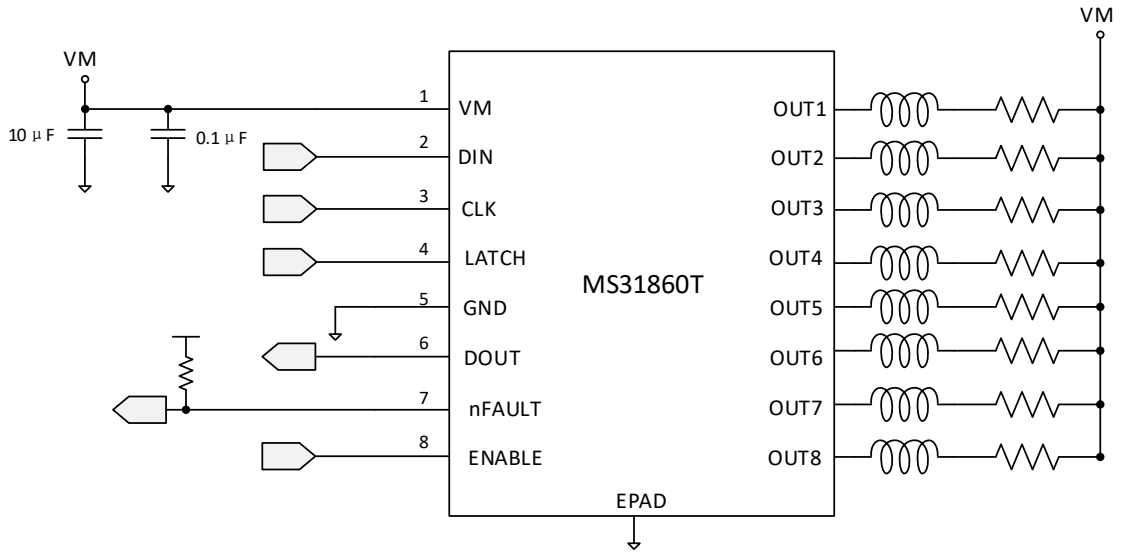
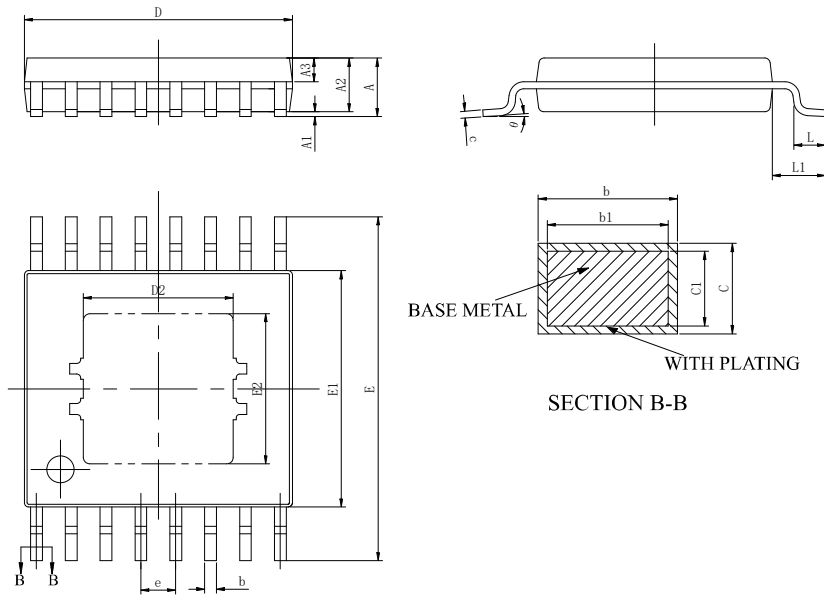

Figure 22. PWM Start Command

TYPICAL APPLICATION DIAGRAM

Typical application diagram is as follows:



PACKAGE OUTLINE DIMENSIONS
eTSSOP16

Symbol	Dimensions in Millimeters		
	Min	Typ	Max
A	-	-	1.20
A1	0.00	-	0.15
A2	0.90	1.00	1.05
A3	0.39	0.44	0.49
b	0.20	-	0.28
b1	0.19	0.22	0.25
c	0.13	-	0.17
c1	0.12	0.13	0.14
D	4.90	5.00	5.10
E	6.20	6.40	6.60
E1	4.30	4.40	4.50
e	0.65BSC		
D2	2.80REF		
L	0.45	-	0.75
L1	1.00BSC		
θ	0	-	8°
E2	2.10REF		

MARKING and PACKAGING SPECIFICATION

1. Marking Drawing Description



Product Name : MS31860T

Product Code : XXXXXXX

2. Marking Drawing Demand

Laser printing, contents in the middle, font type Arial.

3. Packaging Specification

Device	Package	Piece/Reel	Reel/Box	Piece /Box	Box/Carton	Piece/Carton
MS31860T	eTSSOP16	3000	1	3000	8	24000

STATEMENT

- All Revision Rights of Datasheets Reserved for Ruimeng. Don't release additional notice.
Customer should get latest version information and verify the integrity before placing order.
- When using Ruimeng products to design and produce, purchaser has the responsibility to observe safety standard and adopt corresponding precautions, in order to avoid personal injury and property loss caused by potential failure risk.
- The process of improving product is endless. And our company would sincerely provide more excellent product for customer.

**MOS CIRCUIT OPERATION PRECAUTIONS**

Static electricity can be generated in many places. The following precautions can be taken to effectively prevent the damage of MOS circuit caused by electrostatic discharge:

1. The operator shall ground through the anti-static wristband.
2. The equipment shell must be grounded.
3. The tools used in the assembly process must be grounded.
4. Must use conductor packaging or anti-static materials packaging or transportation.



+86-571-89966911



Rm701, No.9 Building, No. 1 WeiYe Road, Puyan Street, Binjiang District, Hangzhou, Zhejiang



[http:// www.relmon.com](http://www.relmon.com)